

Multiple-Choice Test

Chapter 08.04

Runge-Kutta 4th Order Method

1. To solve the ordinary differential equation

$$3\frac{dy}{dx} + xy^2 = \sin x, y(0) = 5,$$

by Runge-Kutta 4th order method, you need to rewrite the equation as

- (A) $\frac{dy}{dx} = \sin x - xy^2, y(0) = 5$
(B) $\frac{dy}{dx} = \frac{1}{3}(\sin x - xy^2), y(0) = 5$
(C) $\frac{dy}{dx} = \frac{1}{3}\left(-\cos x - \frac{xy^3}{3}\right), y(0) = 5$
(D) $\frac{dy}{dx} = \frac{1}{3}\sin x, y(0) = 5$

2. Given $3\frac{dy}{dx} + 5y^2 = \sin x, y(0.3) = 5$ and using a step size of $h = 0.3$, the value of $y(0.9)$ using Runge-Kutta 4th order method is most nearly

- (A) -0.25011×10^{40}
(B) -4297.4
(C) -1261.5
(D) 0.88498

3. Given $3\frac{dy}{dx} + y^2 = e^x, y(0.3) = 5$, and using a step size of $h = 0.3$, the best estimate of

$\frac{dy}{dx}(0.9)$ using Runge-Kutta 4th order method is most nearly

- (A) -1.6604
(B) -1.1785
(C) -0.45831
(D) 2.7270

4. The velocity (m/s) of a parachutist is given as a function of time (seconds) by

$$v(t) = 55.8 \tanh(0.17t), \quad t \geq 0$$

Using Runge-Kutta 4th order method with a step size of 5 seconds, the distance in meters traveled by the body from $t = 2$ to $t = 12$ seconds is estimated most nearly as

- (A) 341.43
- (B) 428.97
- (C) 429.05
- (D) 703.50

5. Runge-Kutta method can be derived from using first three terms of Taylor series of writing the value of y_{i+1} , that is the value of y at x_{i+1} , in terms of y_i and all the derivatives of y at x_i . If $h = x_{i+1} - x_i$, the explicit expression for y_{i+1} if the first five terms of the Taylor series are chosen for the ordinary differential equation

$$\frac{dy}{dx} + 5y = 3e^{-2x}, \quad y(0) = 7,$$

would be

- (A) $y_{i+1} = y_i + (3e^{-2x_i} - 5y_i)h + \frac{5h^2}{2}$
- (B) $y_{i+1} = y_i + (3e^{-2x_i} - 5y_i)h + (-21e^{-2x_i} + 25y_i)\frac{h^2}{2}$
 $+ (-483e^{-2x_i} + 625y_i)\frac{h^3}{6} + (-300909e^{-2x_i} + 390625y_i)\frac{h^4}{24}$
- (C) $y_{i+1} = y_i + (3e^{-2x_i} - 5y_i)h + (-6e^{-2x_i})\frac{h^2}{2} + (12e^{-2x_i})\frac{h^3}{6}$
 $+ (-24e^{-2x_i})\frac{h^4}{24}$
- (D) $y_{i+1} = y_i + (3e^{-2x_i} - 5y_i)h + (-6e^{-2x_i} + 5)\frac{h^2}{2} + (12e^{-2x_i})\frac{h^3}{6}$
 $+ (-24e^{-2x_i})\frac{h^4}{24}$

6. A hot solid cylinder is immersed in a cool oil bath as part of a quenching process. This process makes the temperature of the cylinder, θ_c , and the bath, θ_b , change with time. If the initial temperature of the bar and the oil bath is given as 600°C and 27°C , respectively, and

Length of cylinder = 30 cm

Radius of cylinder = 3 cm

Density of cylinder = 2700 kg/m^3

Specific heat of cylinder = $895\text{ J/kg}\cdot\text{K}$

Convection heat transfer coefficient = $100\text{ W/m}^2\cdot\text{K}$

Specific heat of oil = $1910\text{ J/kg}\cdot\text{K}$

Mass of oil = 2 kg

the coupled ordinary differential equation giving the heat transfer are given by

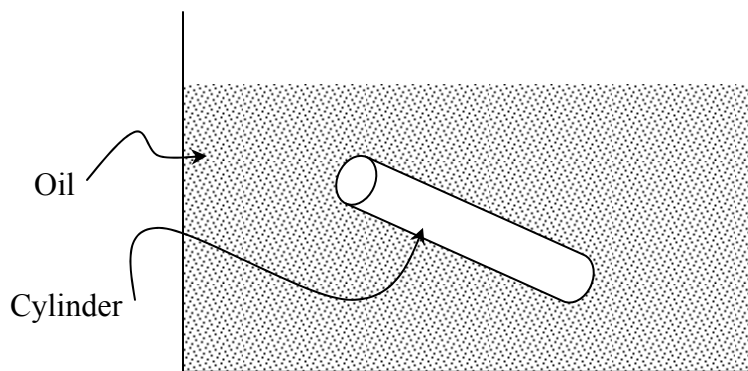

(A) $362.4 \frac{d\theta_c}{dt} + \theta_c = \theta_b$

$675.5 \frac{d\theta_b}{dt} + \theta_b = \theta_c$

(B) $362.4 \frac{d\theta_c}{dt} - \theta_c = \theta_b$

$675.5 \frac{d\theta_b}{dt} - \theta_b = \theta_c$

(C) $675.5 \frac{d\theta_c}{dt} + \theta_c = \theta_b$

$362.4 \frac{d\theta_b}{dt} + \theta_b = \theta_c$

(D) $675.5 \frac{d\theta_c}{dt} - \theta_c = \theta_b$

[Complete Solution](#)