

Chapter 06.00C

Physical Problem for Regression Civil Engineering

Problem Statement

A composite is a structural material that consists of combining two or more constituents. The constituents are combined at a macroscopic level and are not soluble in each other. One constituent is called the *reinforcing phase* and the one in which it is embedded is called the *matrix*. The reinforcing phase material may be in the form of fibers, particles, or flakes. The matrix phase materials are generally continuous. Examples of composite systems include concrete reinforced with steel and epoxy reinforced with graphite fibers, etc.

A special case of composite materials are advanced composites, and are defined as composite materials which are traditionally used in the aerospace industries. These composites have high performance reinforcements of a thin diameter in a matrix material such as epoxy and aluminum. Examples are Graphite/Epoxy, Kevlar¹/Epoxy, and Boron/Aluminum composites. These materials have now found applications in commercial industries as well.

Monolithic metals and their alloys cannot always meet the demands of today's advanced technologies. Only by combining several materials can one meet the performance requirements. For example, trusses and benches used in satellites need to be dimensionally stable in space during temperature changes between -256°F (-160°C) and 200°F (93.3°C). Limitations on coefficient of thermal expansion² hence are low and may be of the order of 1×10^{-7} in/in/ $^{\circ}\text{F}$ (1.8×10^{-7} m/m/ $^{\circ}\text{C}$). Monolithic materials cannot meet these requirements, which leave composites, such as Graphite/Epoxy, as the only materials to satisfy this requirement.

In many cases, using composites is more efficient. For example, in the highly competitive

¹ Kevlar is a registered trademark of E.I. duPont deNemours and Company, Inc., Wilmington, Delaware.

² Coefficient of thermal expansion is the change in length per unit length of a material when heated through a unit temperature. The units are in/in/ $^{\circ}\text{F}$ and m/m/ $^{\circ}\text{C}$. A typical value for steel is 6.5×10^{-6} in/in/ $^{\circ}\text{F}$ (11.7×10^{-6} m/m/ $^{\circ}\text{C}$).

airline market, one is continuously looking for ways to lower the overall mass of the aircraft without decreasing the stiffness and strength of its components. This is possible by replacing conventional metal alloys with composite materials. Even if the composite material costs may be higher, the reduction in the number of parts in an assembly and the savings in fuel costs make them more profitable. Reducing one pound (0.453 kg) of mass in a commercial aircraft can save up to 360 gallons (1360 liters) of fuel per year; and fuel expenses are 25% of the total operating costs of a commercial airline.

The general test method to find the Young's modulus of a composite material is the ASTM Test Method for Tensile Properties of Fiber-Resin Composites (D3039).

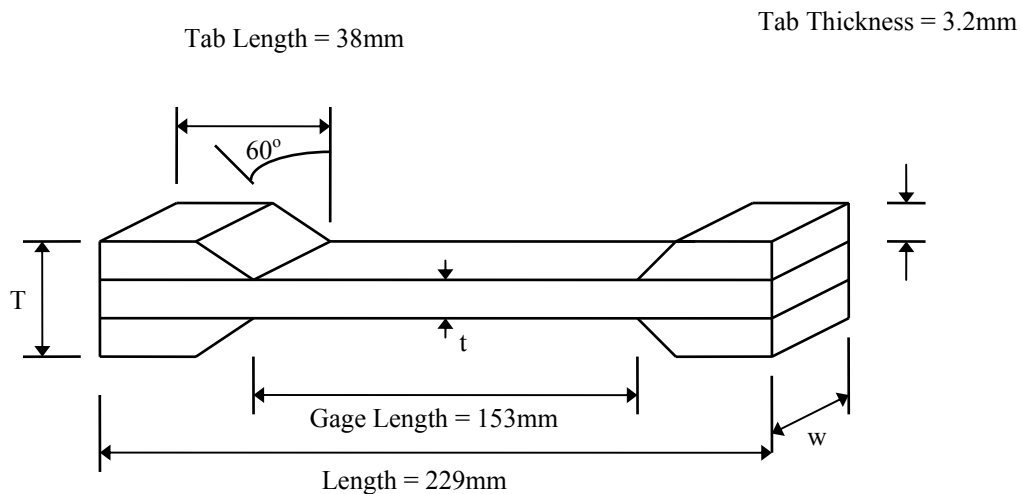

Figure 1 Schematic of Test Specimen used to find the Young's modulus of a composite.

A tensile test geometry (Figure 1) to find the longitudinal tensile strength consists of 6-8 plies of 0° plies which are 12.5 mm (2 inches) wide and 229 mm (10 inches) long. The specimen is mounted with strain gages in the longitudinal and transverse direction. Tensile stresses are applied on the specimen at a rate of about 0.5 - 1 mm/min (0.02 to 0.04 in/min). A total of 40-50 data points for stress and strain are taken until a specimen fails. The stress in the longitudinal direction is plotted as a function of longitudinal strain as shown in Figure 2. The data is reduced using linear regression. The longitudinal Young's modulus is the initial slope of the longitudinal stress, σ_1 vs strain, longitudinal strain, ϵ_1 curve.

Strain (%)	Stress (MPa)
0	0
0.183	306
0.36	612
0.5324	917
0.702	1223
0.867	1529
1.0244	1835
1.1774	2140
1.329	2446
1.479	2752
1.5	2767
1.56	2896

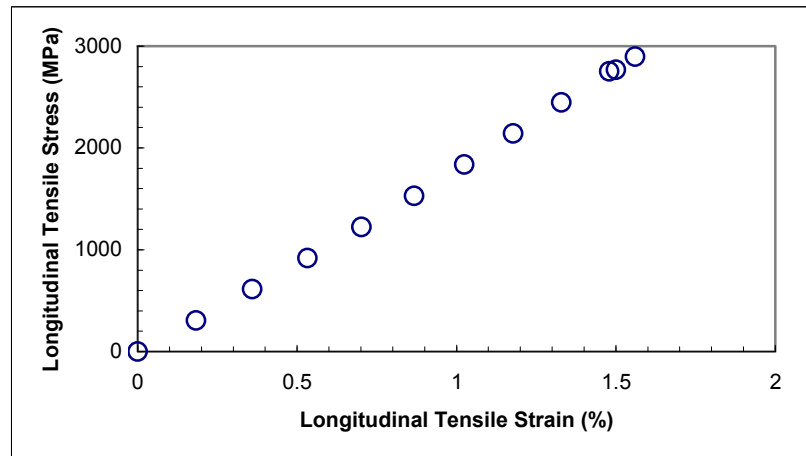

Figure 2 Longitudinal stress as a function of longitudinal strain for a graphite/epoxy composite.

The first order polynomial that one may fit to the data is

$$\sigma = E_1 \varepsilon \quad (1)$$

Questions

1. Find the Young's modulus, E_1 ?
2. What is the longitudinal ultimate tensile strength?
3. What is the longitudinal ultimate strain?
4. What value of E_1 do you get if you use the general linear regression model?

REGRESSION

Topic Physical problem for regression

Summary Find the Young's modulus of a unidirectional graphite/epoxy composite material.

Major Civil Engineering

Authors Autar Kaw

Date December 7, 2008

Web Site <http://numericalmethods.eng.usf.edu>
